

# Vibrating Bin Dischargers

## Eliminate Bridging and Ratholing



**Built To Deliver**  
Vibratory Material Handling and Processing Solutions

**carman**<sup>®</sup>

# Bin Flow Problems

Bin flow problems, including bridging and ratholing, are usually related to one or more of the following conditions:

- Hopper outlet is too small
- Hopper depth is too great
- Hopper slope is too flat

## Bridging

Bridging is a no-flow condition in which the pressure of the stored material on itself results in a self-supporting “bridge” or “arch” formation over the outlet.



## Ratholing

Ratholing is a condition in which the stored material does not slough into the central flow stream for discharge and instead forms a core. Problems associated with ratholing are flooding, substantial variation of density in product, and eventually no-flow.

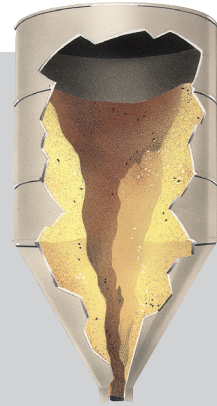

# Carman Bin Discharging Solutions

Carman Vibrating Bin Dischargers offer proven performance advantages including elimination of the two most common bin flow problems while expanding flow in the bin.

## Eliminate Bridging and Ratholing

The Carman Vibrating Bin Discharger eliminates ratholing by increasing the effective hopper outlet size while the unit’s internal pressure cone eliminates bridging.

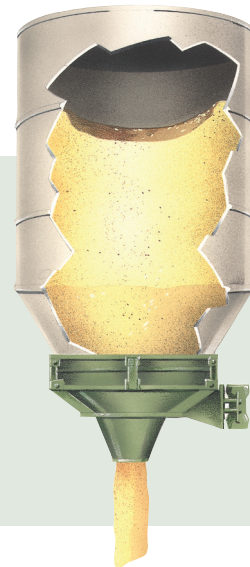

## Expand Flow

After the bin is initially filled (t=0), the Carman Vibrating Bin Discharger will typically expand the channel of flowing product to its diameter. When the product in the center has been sufficiently lowered, the product along the upper/outer walls sloughs off into the flowing channel of product and the cycle repeats (assumes that the bin is not simultaneously being refilled).

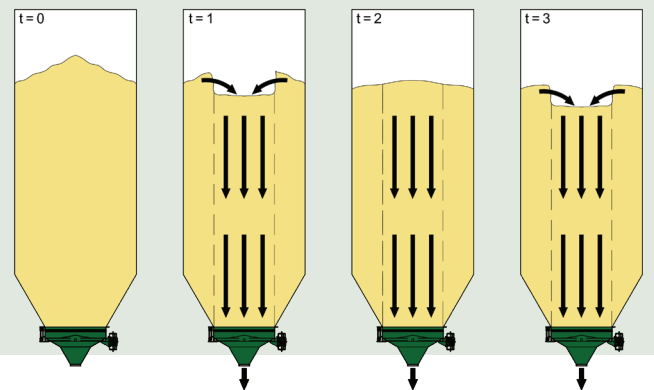

# Bin Discharger Selection & Flowrate Charts

Since 1963, Carman Industries has solved bulk material flow problems for thousands of customers. Selecting the proper Bin Discharger for your application requires that we know the following:

## Bin Information

- Bin Diameter
- Sidewall Height
- Hopper Slope
- Internal Pressure (if any)

## Product Information

- Product Name
- Particle Distribution
- Moisture Content
- Bulk Density
- Temperature

Note that we also request the type of equipment that will be located immediately below the Bin Discharger, the inlet dimensions to this equipment, and its feedrate for interface purposes.

Bulk products are typically grouped into one of three classifications:

Bin Discharger Selection Chart	Storage Bin with 60° Hopper	Bin Discharger Diameter
<b>Class I:</b> These products are predominately granular with few fines, no moisture, and generally have fairly good flow properties. Examples: plastic pellets and pebble lime.	2'-8'	2'-3'
	8'-12'	3'-4'
	12'-15'	4'-5'
	15'-up	5'-up
<b>Class II:</b> These products are either a combination of granules and powders or predominately powders with very little cohesive strength. Examples: hydrated lime, hard wheat flour, starch, talc, flyash, and soda ash.	2'-5'	2'-3'
	5'-8'	3'-4'
	8'-12'	4'-5'
	12'-15'	5'-6'
	15'-up	6'-up
<b>Class III:</b> These products are very fine powders with both high cohesive strength and compressibility. Examples: calcium carbonate, kaolin clay, soft winter wheat flour, soy flour, and titanium dioxide.	2'-4'	2'-3'
	4'-7'	3'-4'
	7'-11'	4'-6'
	11'-15'	6'-8'
	15'-up	8'-up

Since Bin Dischargers are flow-promoting (not flow-regulating) devices, most projects include a Bin Discharger to promote flow and some type of feeder located immediately below the Bin Discharger to meter the material from storage at the desired rate. In those few instances when flow-regulating equipment does not exist, i.e., the Bin Discharger discharges directly into a truck, railcar, supersack, etc., then please note the approximate flow rates in this chart (see assumptions below):

Flowrate Chart	8" Diameter Outlets	10" Diameter Outlets	12" Diameter Outlets	14" Diameter Outlets
Class I Products	2,100 CFH	3,500 CFH	5,300 CFH	7,400 CFH
Class II Products	1,000 CFH	2,000 CFH	3,000 CFH	4,000 CFH
Class III Products	Not Recommended	1,500 CFH	2,500 CFH	3,500 CFH

Flowrate chart assumes the following:

- 1) There are no obstructions (e.g., butterfly valve disk) below the Bin Discharger
- 2) The Bin Discharger has been energized long enough to reach normal operating speed

# The Carman 30°/60° Vibrating Bin Discharger

A unique design with all the hardware to install quickly...and the ruggedness to run 24/7.

Carman's 30°/60° cone design offers proven performance advantages when compared to competitive single slope or dished-head designs including the ability to discharge some products that cannot be discharged from shallower sloped designs.

## Adapter Ring

The adapter ring is used to attach the vibrating bin discharger to the bin or hopper section of the bin. It provides an attachment point for the inlet sock and properly positions the hanger arm support points.

Adapter rings are available for either weld-on or bolt-on installation. The typical weld-on adapter ring simply welds directly to the bin. When a bolt-on adapter ring is supplied, there must be a mating flange on the outlet of the storage bin.

Some customers prefer the less expensive weld-on adapter ring, while other customers prefer the bolt-on adapter ring option which permits the bin discharger to ship fully assembled and greatly simplifies final installation in the field.

## Inlet Sock

The inlet sock provides the seal between the storage bin and the bin discharger. Carman's standard sock material is a reinforced EPDM elastomer...extremely tough, yet flexible to allow proper vibratory motion. Our EPDM elastomers are superior to neoprene connectors regarding resistance to the effects of both sunlight and ozone.

Other elastomers, including FDA approved connectors, 3A sanitary 18-03 connectors and high temperature/pressure connectors, are also available.

## Sock Fasteners

Stainless steel fasteners are used to secure inlet socks.

Standard double drawbands are used for low pressure applications (up to 5 psig). 10 psig and 14.5 psig designs are also available.

## Hanger Arms

Carman's high strength ductile iron hanger arms are custom engineered for vibratory service and matched to your application.

Rubber bushings, located in the top and bottom eyelets of the hanger arm, allow maximum horizontal bin discharger movement to promote material flow, yet minimize reactions into the bin. Special bushings are available for high temperature use.

## Special Features and Accessories

Carman has developed special equipment and accessories to

solve unique storage flow problems including:

- Carbon steel, stainless steel and other special materials of construction
- UHMW liners
- Special finishes including epoxy, polyurethane, and high temperature finishes
- Sanitary designs
- Dual outlet configuration
- Flanged outlets
- Flanged flexible connectors
- Maintenance gates (both manual and automatic)

## Drive Motor

Vibratory motors used to drive Carman bin dischargers are foot-mounted and include a 30 month warranty. Motors have double extended shafts complete with adjustable eccentric weights.

Totally enclosed non-ventilated (TENV) and explosion-proof designs are available. Explosion-proof ratings are Class I, Groups C and D; and Class II, Groups E, F, and G service.

## Pressure Cone

The Carman pressure cone provides relief of headload pressure off the outlet.

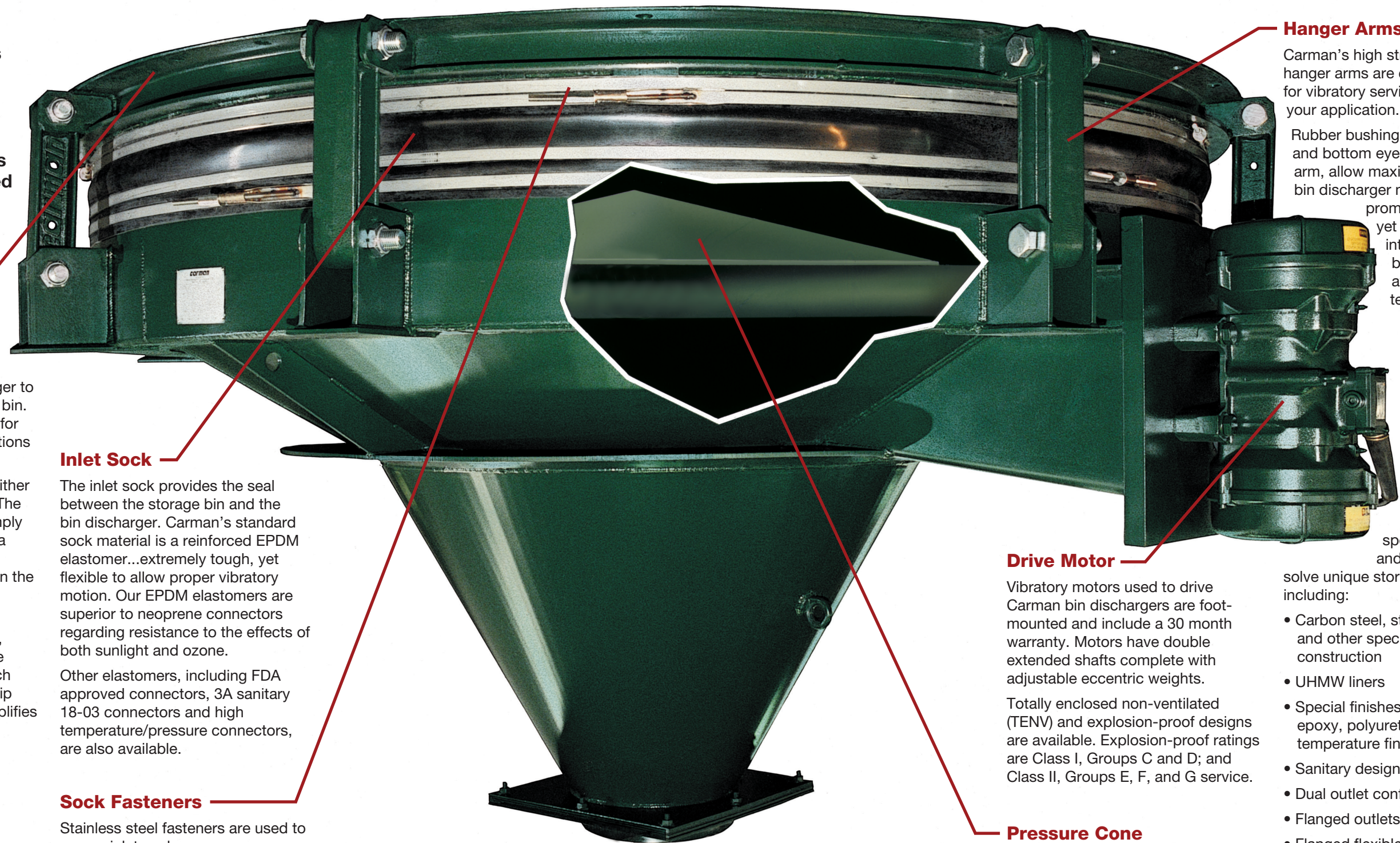

# Carman 30°/60° Bin Discharger

# Carman 45° Bin Discharger

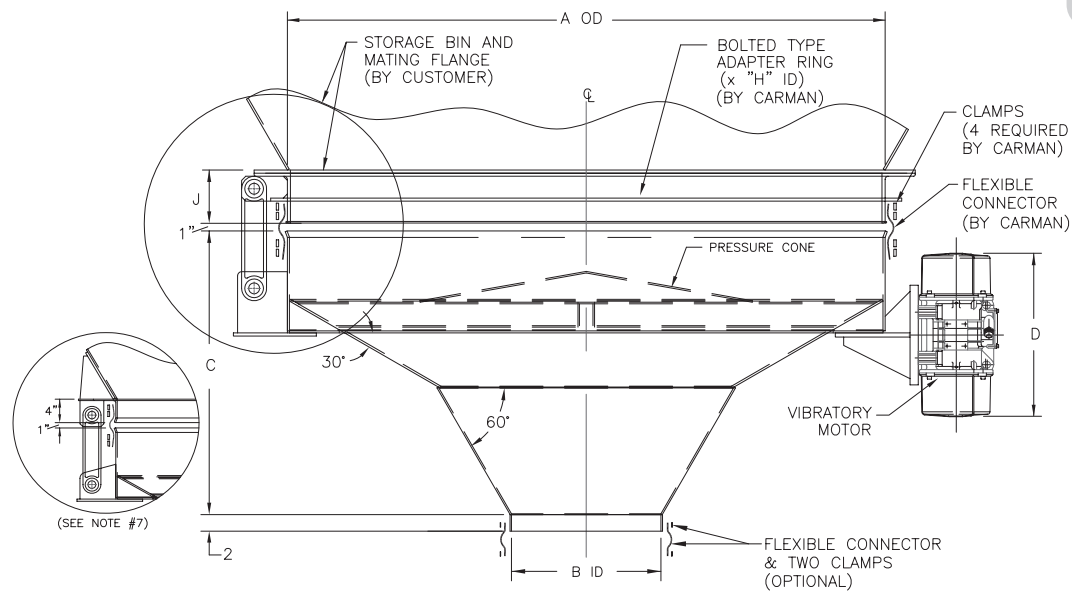
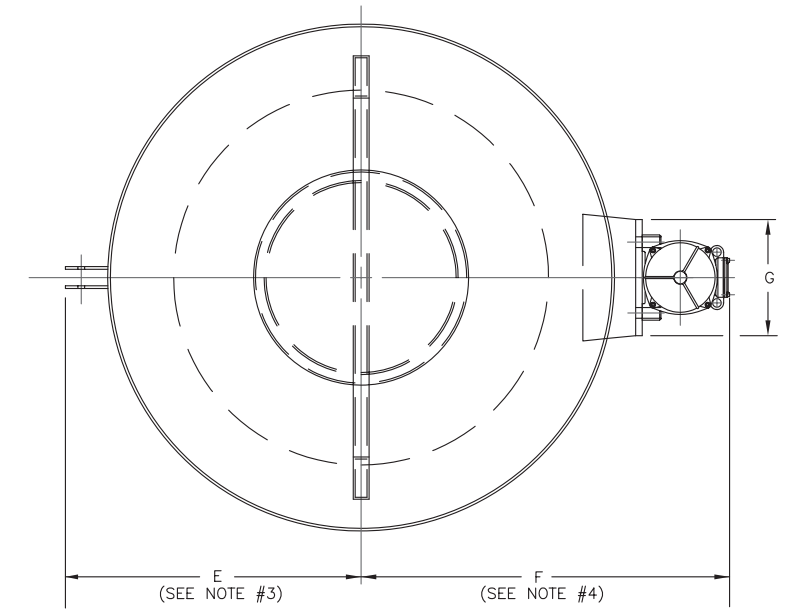
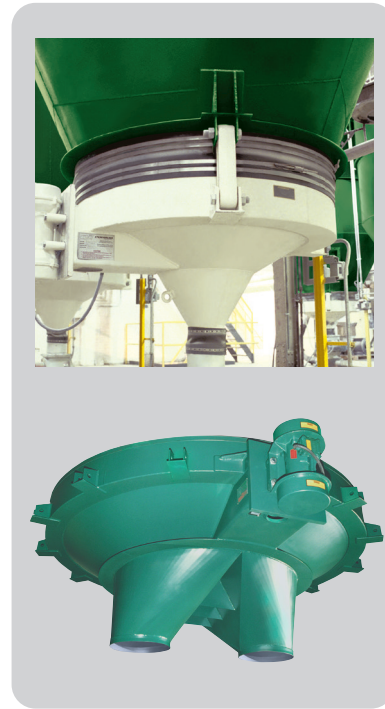
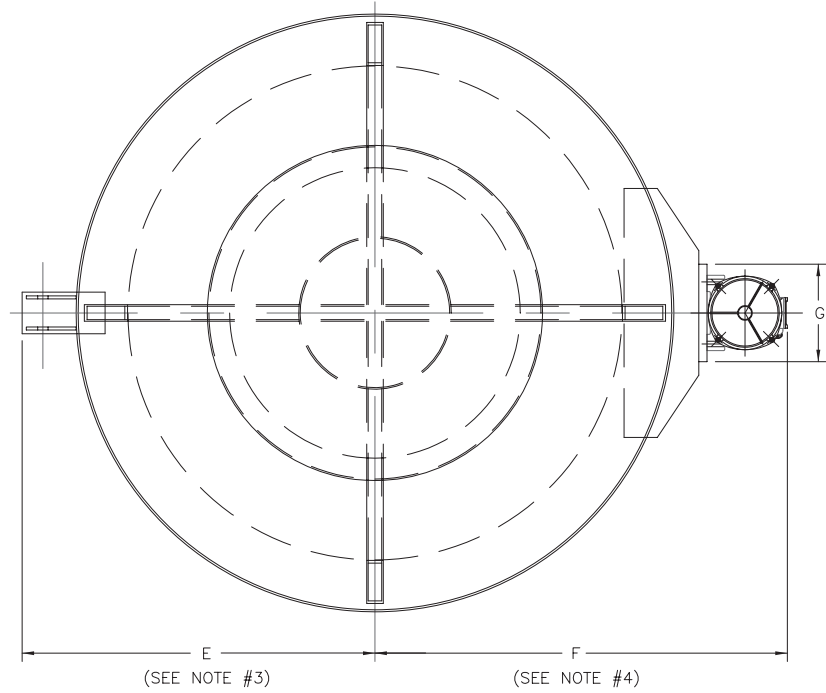

## Optional Outlet Configurations (For Either Design)

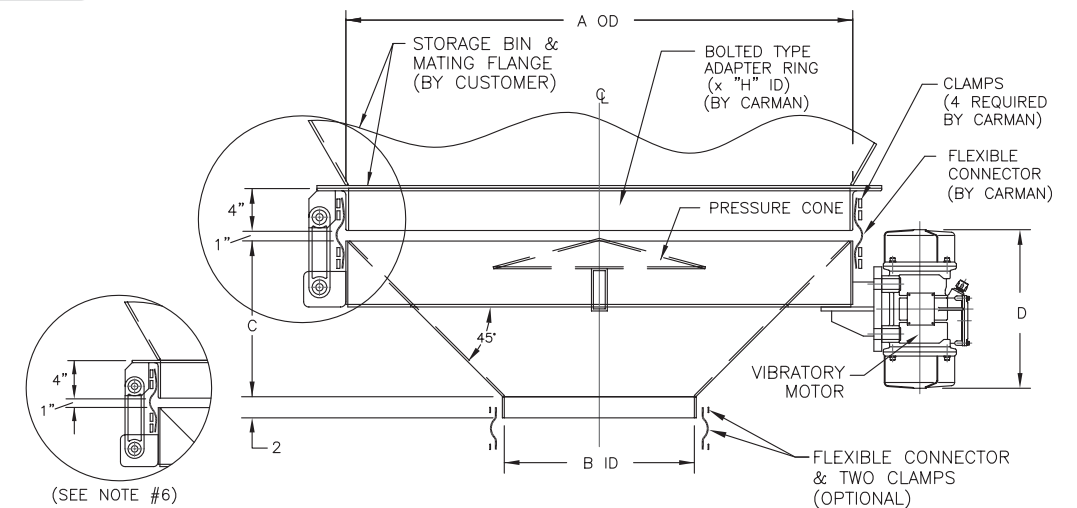
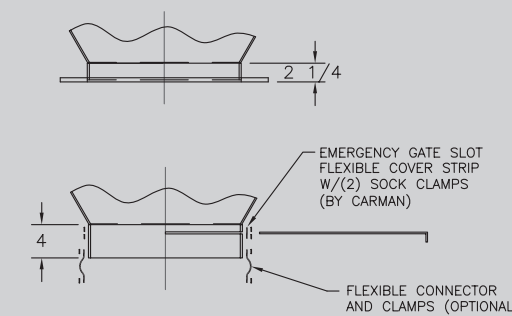

MODEL NO.	HP	A	B (OUTLET SIZE)						D (MAX)	E	F (MAX)	G	H	J	WGT (LBS)
			8	10	12	14	16	18							
5 GBD	1.5	60	39 <sup>9</sup> / <sub>16</sub>	37 <sup>7</sup> / <sub>16</sub>	35 <sup>5</sup> / <sub>16</sub>	34 <sup>3</sup> / <sub>16</sub>	32 <sup>1</sup> / <sub>16</sub>	30 <sup>11</sup> / <sub>16</sub>	21 <sup>3</sup> / <sub>8</sub>	36 <sup>1</sup> / <sub>2</sub>	45 <sup>1</sup> / <sub>2</sub>	11 <sup>3</sup> / <sub>4</sub>	59 <sup>1</sup> / <sub>4</sub>	6	1300
6 GBD	1.5	72	42 <sup>11</sup> / <sub>16</sub>	41	39 <sup>9</sup> / <sub>16</sub>	37 <sup>7</sup> / <sub>16</sub>	35 <sup>5</sup> / <sub>16</sub>	34	21 <sup>3</sup> / <sub>8</sub>	42 <sup>1</sup> / <sub>2</sub>	51 <sup>1</sup> / <sub>2</sub>	11 <sup>3</sup> / <sub>4</sub>	71 <sup>1</sup> / <sub>4</sub>	6	1750
7 GBD	1.5	84	46 <sup>1</sup> / <sub>4</sub>	44 <sup>1</sup> / <sub>2</sub>	42 <sup>13</sup> / <sub>16</sub>	41 <sup>1</sup> / <sub>16</sub>	39 <sup>9</sup> / <sub>16</sub>	37 <sup>7</sup> / <sub>16</sub>	21 <sup>3</sup> / <sub>8</sub>	48 <sup>1</sup> / <sub>2</sub>	57 <sup>1</sup> / <sub>2</sub>	11 <sup>3</sup> / <sub>4</sub>	83 <sup>1</sup> / <sub>4</sub>	6	2375
8 GBD	3.0	96	56 <sup>11</sup> / <sub>16</sub>	54 <sup>15</sup> / <sub>16</sub>	53 <sup>3</sup> / <sub>4</sub>	51 <sup>1</sup> / <sub>2</sub>	49 <sup>3</sup> / <sub>4</sub>	48 <sup>1</sup> / <sub>16</sub>	27	54 <sup>1</sup> / <sub>2</sub>	67	17	95 <sup>1</sup> / <sub>4</sub>	6	3075
9 GBD	3.0	108	60 <sup>3</sup> / <sub>8</sub>	58 <sup>3</sup> / <sub>8</sub>	56 <sup>3</sup> / <sub>8</sub>	54 <sup>15</sup> / <sub>16</sub>	53 <sup>3</sup> / <sub>16</sub>	51 <sup>7</sup> / <sub>16</sub>	27	60 <sup>1</sup> / <sub>2</sub>	73	17	107	8	3413
10 GBD	3.0	120	63 <sup>9</sup> / <sub>16</sub>	61 <sup>13</sup> / <sub>16</sub>	60 <sup>3</sup> / <sub>8</sub>	58 <sup>3</sup> / <sub>8</sub>	56 <sup>3</sup> / <sub>8</sub>	54 <sup>15</sup> / <sub>16</sub>	27	66 <sup>1</sup> / <sub>2</sub>	79 <sup>1</sup> / <sub>2</sub>	17	119	8	3750
12 GBD	7.5	144	70 <sup>7</sup> / <sub>16</sub>	68 <sup>11</sup> / <sub>16</sub>	67	65 <sup>1</sup> / <sub>4</sub>	63 <sup>1</sup> / <sub>2</sub>	61 <sup>13</sup> / <sub>16</sub>	29 <sup>3</sup> / <sub>4</sub>	78 <sup>1</sup> / <sub>2</sub>	93 <sup>1</sup> / <sub>2</sub>	31	143	8	6100

MODEL NO.	HP	A	B (OUTLET SIZE)						D (MAX)	E	F (MAX)	G	H	WGT (LBS)
			8	10	12	14	16	18						
2 GBD	0.5	24	7 <sup>3</sup> / <sub>4</sub>	6 <sup>3</sup> / <sub>4</sub>					13 <sup>5</sup> / <sub>8</sub>	16 <sup>3</sup> / <sub>4</sub>	25	10	23 <sup>1</sup> / <sub>2</sub>	350
3 GBD	0.75	36	13 <sup>3</sup> / <sub>4</sub>	12 <sup>3</sup> / <sub>4</sub>	11 <sup>3</sup> / <sub>4</sub>	10 <sup>3</sup> / <sub>4</sub>			15	22 <sup>3</sup> / <sub>4</sub>	31	10	35 <sup>1</sup> / <sub>2</sub>	500
4 GBD	0.75	48	19 <sup>3</sup> / <sub>4</sub>	18 <sup>3</sup> / <sub>4</sub>	17 <sup>3</sup> / <sub>4</sub>	16 <sup>3</sup> / <sub>4</sub>	15 <sup>3</sup> / <sub>4</sub>	14 <sup>3</sup> / <sub>4</sub>	15	28 <sup>3</sup> / <sub>4</sub>	37	10	47 <sup>1</sup> / <sub>2</sub>	600
5 GBD and LARGER (See Note #8)														

- NOTES:**
- Drawing is for reference only.
  - All dimensions are in inches.
  - "E" is the minimum radial clearance required for isolation.
  - "F" is the minimum radial clearance required for drive.
  - Overall height is a function of outlet size "B".
  - Optional view shows Carman's welded adapter ring which eliminates the need for a mating flange, and, since 2" thru 4" units utilize Carman's standard duty hanger arms, bearing plates and gussets are not required.
  - Optional view shows Carman's welded adapter ring which eliminates the need for a mating flange, but does require a bearing plate and two gussets, by others, to be located above each hanger arm location.
  - For 5' diameter and larger Bin Dischargers, Carman often recommends a 30°/60° design due to its steeper lower cone, but some applications permit the use of either design, and the 45° unit usually requires less headroom. Should a larger 45° unit be desired, please call Carman to discuss.
  - Formed edge or 3/16" diameter bead rings may be used for adapter rings.

# **Built To Deliver**

**Vibratory Material Handling  
and Processing Solutions**

## **Expertise To Meet Your Processing Needs**

Since 1961, Carman Industries has solved difficult material handling and processing problems with solutions that are “Built To Deliver.”

Our problem solving expertise has earned us the confidence of dozens of Fortune 500 companies who rely on our solutions to process their products day in and day out.

With more than 60 years of vibratory material handling and processing application experience in a variety of materials, chances are we have proven equipment installations solving problems similar to yours.

Talk to us about your application. We'll share decades of innovations and hands-on expertise to develop the ideal solution for your processing needs.

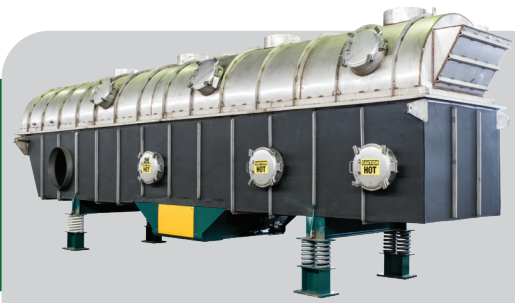

**Heat Dry Cool**



**Convey**



**Feed**

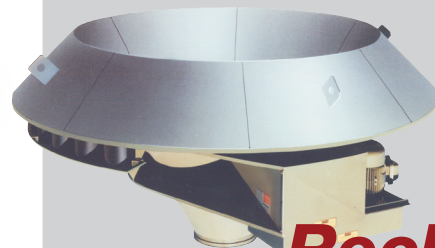

**Reclaim**



**Elevate**



**carman**®

1005 W. Riverside Drive • Jeffersonville, IN 47130  
800-456-7560 • FAX: 812-288-4708  
info@carmanindustries.com

**www.carmanindustries.com**