

Roller Gates Series N

Standard Features

- Use in high cycle gravity flow applications
- Unobstructed orifice ensuring product does not hang up
- Positive blade lock (PBL) between blade & cylinder rod
- Internal magnetic piston, cushioned air cylinder
- Stainless Steel blade
- Narrow profile, light weight Aluminum frame
- Adjustable polymer cam rollers for dust tight seal on blade
- Constant pressure nylon seals on blade
- Fully lined polymer interior with Stainless Steel seal retainers
- Regular flange patterns or CEMA flanges to match screw conveyors
- Removable bonnet seal
- Standard gate rated for 82° C (180° F)
- Fully tested prior to shipping



Dual Air Cylinder Roller Gates available as an option for space constraints

Options

- Solenoids - single or double acting 110 volt AC & 24 volt DC NEMA 4 (available NEMA 7/9)
- Oversized air cylinders
- Pre-wired Terminal Boxes
- Hand wheel, hand crank, electric or chain wheel actuation
- Position switches mounted on air cylinder 5 volt to 240 volt AC/DC
- High temperature modifications available
- Stainless Steel construction
- Clear covers
- Special Service Inlet
- Vented Ball Valve (safety feature)
- Mufflers (Flow Control or Quick Exhaust)
- Filter/Regulator/Lubricator
- Variable or Infinite Position Controls
- Rectangular options available

Regular Flange

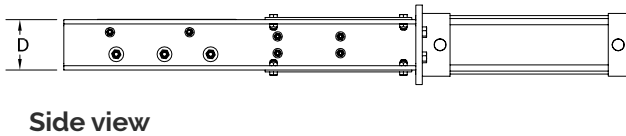
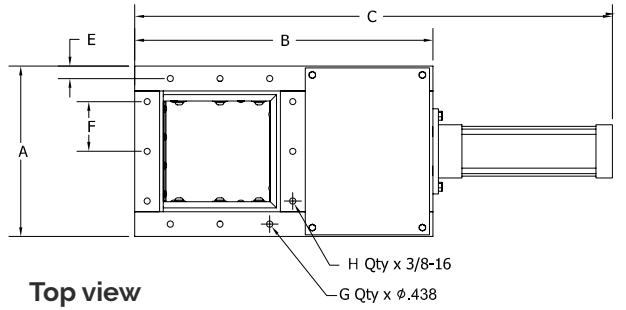

SIZE	A	B	C	D	E	F	G Qty x 0.44"Ø	H Qty x 3/8-16 Tap
6"	10.00	17.00	27.63	3.00	0.88	4.13	6	2
8"	12.00	21.00	33.63	3.00	0.88	3.50	9	3
10"	14.00	25.00	39.63	3.00	0.88	4.50	9	3
12"	16.00	29.00	45.63	3.00	0.88	2.75	15	5
14"	18.00	33.00	51.88	3.00	0.88	3.25	15	5
16"	20.00	37.00	57.88	3.00	0.88	3.75	15	5
18"	22.00	41.00	63.88	3.00	0.88	4.25	15	5
20"	24.00	45.00	69.88	3.00	0.88	3.00	21	7
22"	26.00	49.00	75.88	3.00	0.88	3.50	21	7
24"	29.00	NA	85.00	4.00	1.38	3.75	21	7
30"	35.00	NA	103.81	4.00	1.38	3.63	27	9
32"	37.00	NA	109.81	4.00	1.38	3.63	27	9
34"	39.00	NA	115.81	4.00	1.38	3.13	33	11
36"	41.00	NA	121.94	4.00	1.38	3.31	33	11

CEMA Flange

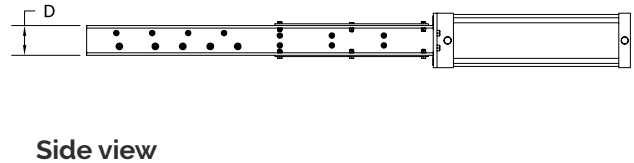
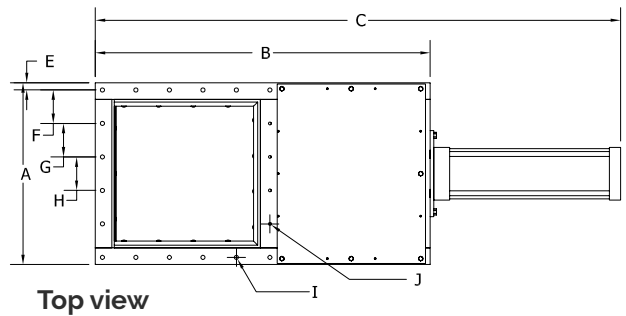

SIZE	A	B	C	D	E	F	G	H	I	J
7"	11.00	19.00	30.63	3.00	1.19	2.81	NA	3.00	10x.44	2x3/8-16
9"	14.00	25.00	39.63	3.00	1.00	4.00	NA	4.00	10x.44	2x3/8-16
11"	15.00	27.00	42.63	3.00	1.00	4.31	NA	4.38	10x.44	2x3/8-16
13"	17.00	31.00	48.62	3.00	0.75	5.13	NA	5.25	10x.44	2x3/8-16
15"	19.00	35.00	54.88	3.00	0.75	3.50	3.50	3.50	16x.44	4x3/8-16
17"	21.00	40.00	61.88	3.00	0.75	3.75	4.00	4.00	16x.44	4x3/8-16
19"	23.00	43.00	66.88	3.00	0.50	4.44	4.38	4.38	16x.56	4x1/2-13
21"	25.00	47.00	72.88	3.00	0.50	4.88	4.75	4.75	16x.56	4x1/2-13
25"	30.00	NA	88.50	4.00	1.00	5.63	5.63	5.50	16x.56	4x1/2-13

**Aluminum
construction
standard**